

# THE TEV<sup>®</sup> TRAILER EMERGENCY VALVE

## THE TRAILER EMERGENCY VALVE PROVIDES SPRING BRAKE PRIORITY LOGIC

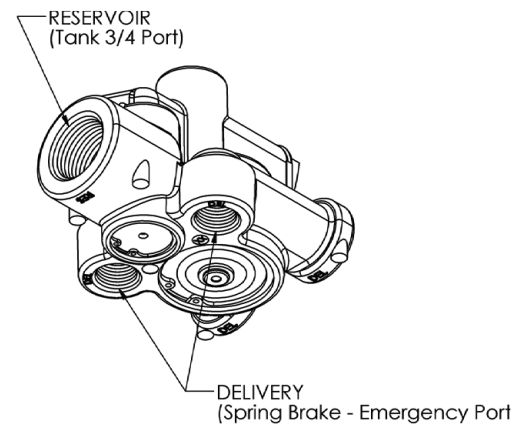
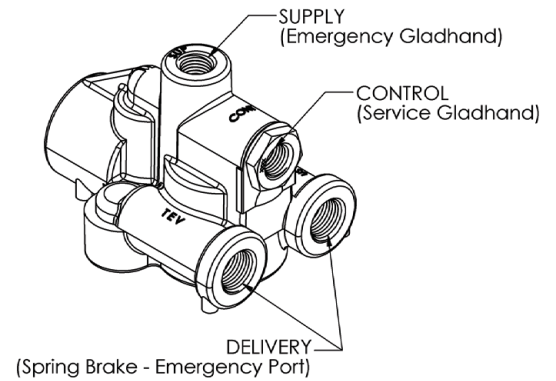

### EXCLUSIVE TEV<sup>®</sup> FEATURES & BENEFITS

Tramec Sloan's TRAILER EMERGENCY VALVE (TEV) provides spring brake priority for direct control of trailer spring brakes. The logic of the TEV valve retains the ability of the driver to repeatedly apply and release the Parking/Emergency brakes, even with a damaged tank.

- Provides Trailer Spring Brake Control and Gladhand Pressure Protection as Required by DOT 121
- Prevents Spring Brake Drag
- **SEALED HARD ANODIZED FINISH – 200+ HOURS SALT SPRAY RESISTANCE**
- Use a Single Air Tank – Allows the Elimination of the Protected Reservoir
- Small Size is Gentle on Tanks, Weigh Less than Two Pounds
- Easy Installation & Conversion from Old Systems
- Fully Compatible with Anti-Lock Systems

### REPLACES:

Bendix SR-5, SRC-7000; Sealco 110500, 110800; Haldex KN26120

### THE TEV<sup>®</sup>

P/N	DESCRIPTION	SUPPLY PORT	CONTROL PORT	RESERVOIR PORT	DELIVERY PORTS (X4)
51301	TEV Assembly	1/4-18	1/4-18	3/4-14	3/8-18
51302	TEV Assembly	3/8-18	3/8-18	1/2-14	3/8-18
51305	TEV Rebuild Kit	-	-	-	-

# THE TEV<sup>®</sup> TRAILER EMERGENCY VALVE

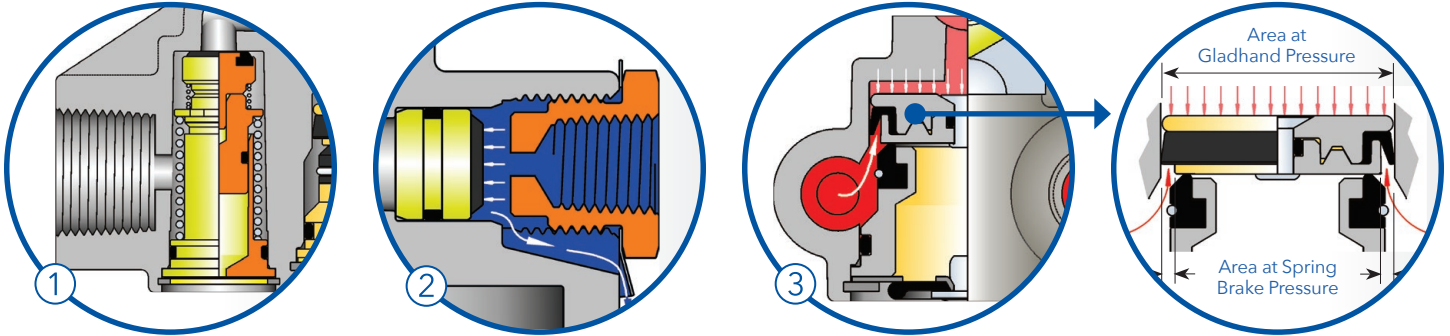

- 1. PRESSURE PROTECTION:** When the supply line pressure exceeds 85 psi, the piston shifts down to allow flow to the tank. The check valve retains tank pressure when the gladhand is vented.
- 2. VENTING ANTI-COMPOUNDING:** When the Spring Brakes are On, the Control line is Vented to Atmosphere. Prevents false release of Spring Brakes on Doubles; Ejects fluids trapped in Control Lines.
- 3. By Design,** the Spring Brakes will retain the maximum pressure delivered by the compressor, until the supply gladhand pressure drops to about 35 psi. The effective area of the shuttle at gladhand pressure is about 3 times that of the area exposed to spring brake pressure.  $\text{Area} \times \text{Pressure} = \text{the Force to Retain or Exhaust the pressure in the spring brakes.}$

## RESERVOIR CHARGING:

- Supply
- Spring Brakes
- Tank

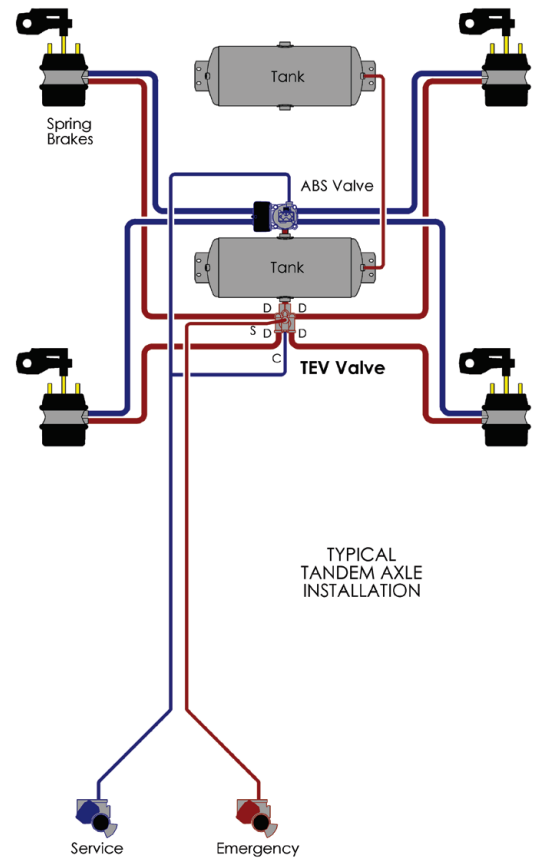
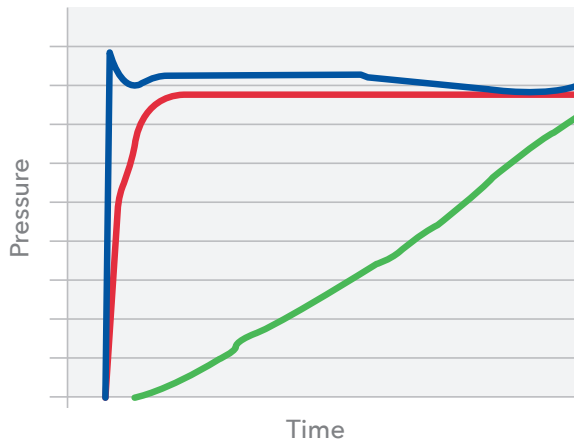

Tramec Sloan, LLC.  
 TRAMECSLOAN.COM  
 P: 800.336.7778  
 F: 877.286.6515

LIT-FS-37 | V. 071217

FOLLOW US ON TWITTER! @TRAMECSLOAN